

# COMPARISON OF DIFFERENTIAL PRESSURE SENSING TECHNOLOGIES IN HOSPITAL ISOLATION ROOMS AND OTHER CRITICAL ENVIRONMENT APPLICATIONS

APPLICATION NOTE LC-136

---

## Introduction

Specialized spaces often times must be maintained at a positive or negative pressure to ensure safety and compliance to standards. For example, Hospital Isolation Rooms are typically classified as either an Airborne Infection Isolation (AII) Room (Negative to hallway) or Protective Environment (PE) room (Positive to hallway). These rooms are designed to comply with various standards such as ASHRAE 170-2008, FGI/AIA 2010, CDC, and ASHE. To comply with the standards, these rooms typically are set up to maintain a small pressure differential relative to a hallway or anteroom. This pressure is stipulated in the standards as a minimum of 0.01 in. H<sub>2</sub>O (2.5 Pa). This application note looks at the different technologies used in the market today to meet this need, focusing on the overall sensor performance.

---

## Available Technologies

When designing a pressure control system for critical applications, like hospital isolation rooms, it can be challenging to understand the differences in available pressure sensing technologies. The two available technologies on the market today include a Through-the-Wall (TTW) anemometer-based sensor and a pressure transducer based on capacitive resistance.

A TTW sensor uses thermal anemometry to sense air flow and converts that data into an extremely accurate pressure reading. Thermal anemometers have a reputation for high repeatability, high sensitivity, stability, and minimal sensor-to-sensor variation. Thus, they have been considered very reliable and safe when it comes to sensing room pressure. Anemometry is accepted and widely used in HVAC tools like air velocity meters.

The TTW assembly consists of two air velocity sensors and a temperature compensation sensor. The velocity sensors are heated to 35°C above the ambient air temperature. The temperature compensation sensor corrects for changes in the ambient air temperature, forcing the velocity sensors to remain at constant temperature over the ambient air temperature (constant overheat).



The velocity sensors and temperature sensor form two legs of a Wheatstone bridge as shown in Figure 1. The bridge circuit forces the voltages at points A and B to be equal. Air flowing past the velocity sensors cools the sensors and reduces their resistance. This causes the voltage at point A to decrease. The operational amplifier instantly responds to this change by increasing the power at the top of the bridge until the voltage at point A increases and is equal to the voltage at point B. As more air flows past the sensors, more power is required to maintain a balanced bridge. Thus, the power required at the top of the bridge to maintain a constant overheat is directly related to the pressure of the air flowing past the sensor. This is the principal of operation of all constant-overheat thermal anemometers.

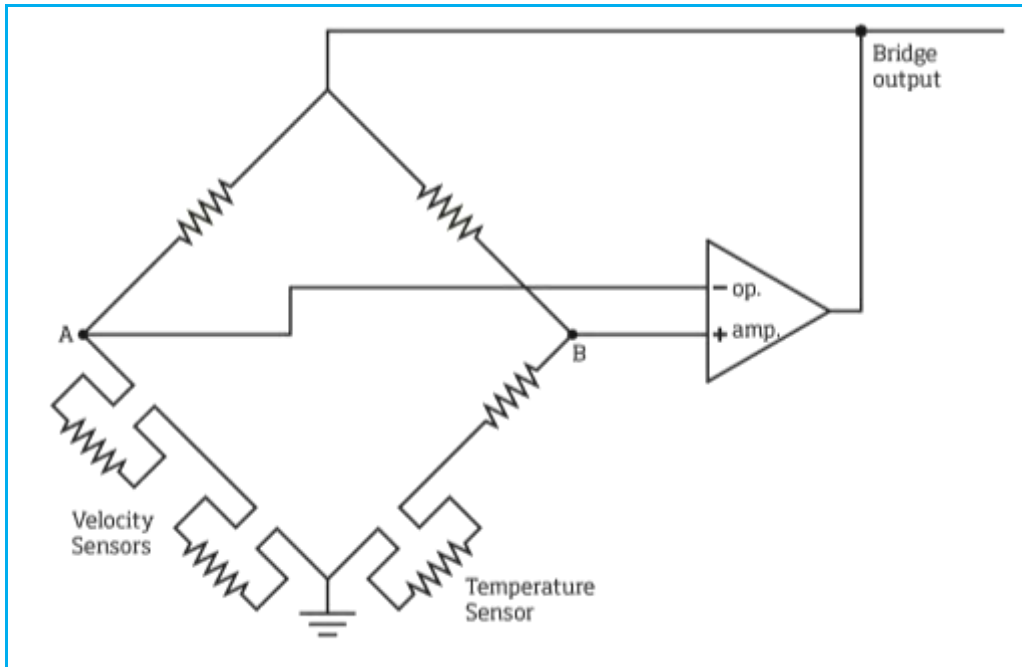

**Figure 1.** Principle of Thermal Anemometry Based Pressure Sensor

Traditionally, pressure transducers have been inaccurate at the low pressure ranges found in isolation rooms and other specialized spaces. In addition, they have stability issues and require regular calibration checks to verify proper operation. TSI is familiar with these challenges, as we incorporate a pressure transducer in our Capture Hoods used for Test and Balance applications. Accordingly, TSI had to design a self calibrating element to continually compensate for this phenomenon in order to obtain accurate readings.

A capacitive pressure transducer measures the pressure differential between two separate areas by measuring the gap between one fixed diaphragm and one fluctuating diaphragm. The pressure of the two different spaces is fed back to the sensor via plastic tubing run through the walls, which is connected to the spaces via special wall plates. As the fluctuating diaphragm bows and deforms with pressure variations, the change in the gap between the fixed diaphragm and the fluctuating diaphragm is measured via capacitance, and a pressure value is then calculated. Figure 2 shows a pictorial representation of a pressure transducer.

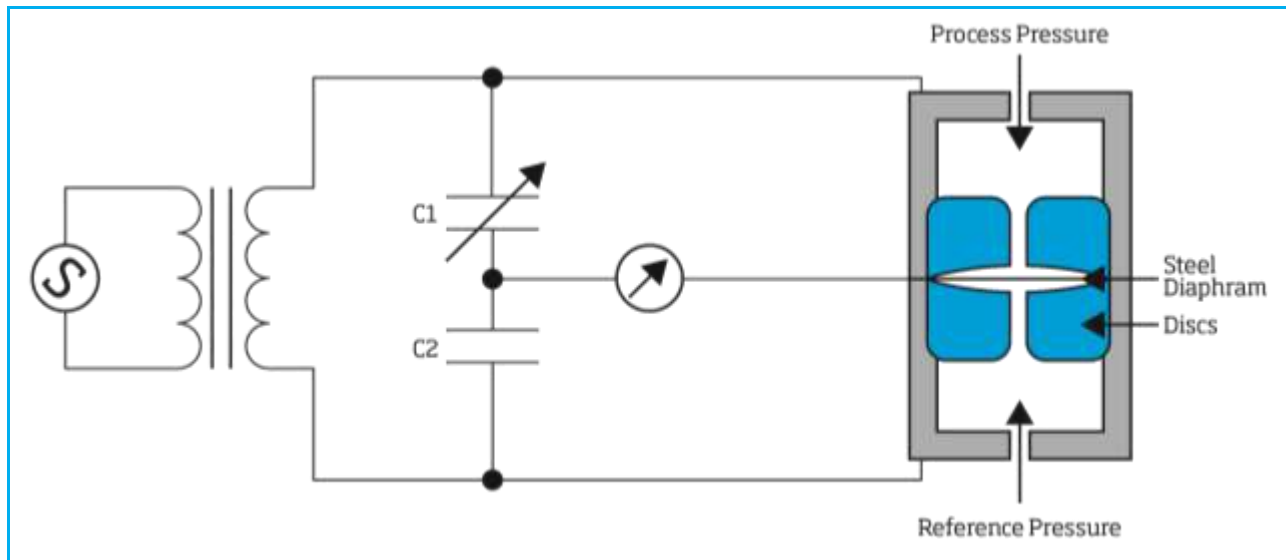

**Figure 2.** Principle of a Capacitive Pressure Transducer

There are several key issues to consider when selecting a pressure sensing device to meet the stringent requirements for hospital isolation rooms and other specialized spaces. These include the true accuracy of the sensor (the total error), the drift, and calibration.

## Accuracy

Sensor accuracy is paramount for safety and energy efficiency in critical spaces. The guidelines state the pressure differential cannot go below 0.01 in. H<sub>2</sub>O, and critical spaces are typically designed to operate very near 0.01 in H<sub>2</sub>O in order to conserve energy and not have over pressurization issues. If the sensor produces inaccurate readings, the contaminants you are trying to protect your clean environments from can migrate from the polluted area to the clean area. In terms of energy efficiency, if a sensor is not accurate enough you may have to over pressurize rooms in order to keep the room at a safe pressure that falls within the range of error of the sensor.

Accuracy ratings are published by all pressure sensing device manufacturers, but can be confusing. Accuracy ratings can be based on full scale (FS) of the sensor, or based on the actual reading. The difference between the two ratings can be substantial. An accuracy rating compared to the FS of the sensor looks great compared to a rating based on actual reading but in reality, the FS rating may not be as good as it first appears. Other error causes are typically not included in the FS accuracy rating. Only when those errors are accounted for, and applied to an actual reading can you determine the true accuracy. In comparison, the accuracy at actual reading is a no-nonsense look at the total error of an actual reading.

For TSI's TTW sensor, the **true** accuracy is specified at  $\pm 10\%$  of the **actual** reading. For example,  $\pm 10\%$  of an actual reading of a point of 0.012 in. H<sub>2</sub>O (higher than 0.01 in. H<sub>2</sub>O to meet conform to standards), would have a true accuracy of 0.012 in. H<sub>2</sub>O x 10%, or

$$\mathbf{0.012 \text{ in. H}_2\text{O} \times \pm 10\% \text{ of reading} = \pm 0.0012 \text{ in. H}_2\text{O} \text{ of actual reading}}$$

For a pressure transducer, you really have to look at what is reported and what it truly means. Most pressure transducer manufacturers state the accuracy based on FS using the Root Sum Square (RSS) method to combine linearity, hysteresis, and non-repeatability. A careful look at their specifications and application notes reveals that there are actually nine error sources:

- 1) Non-linearity – relationship between a calibration curve and a specific straight line (included in typical accuracy specification)
- 2) Hysteresis – value of a physical property lags behind changes in the effect causing it (included in typical accuracy specification)
- 3) Non-repeatability - ability to reproduce the same readings under the exact same conditions (included in typical accuracy specification)
- 4) Long term stability – deviation to reproduce the same results as the original with respect to time
- 5) Zero Offset – deviation in output from the ideal point at zero
- 6) Span Offset – deviation in maximum span output signal of a pressure sensor from the ideal value at full scale pressure
- 7) Thermal effect on offset – effect the temperature has on the offset
- 8) Thermal effect on span – effect the temperature has on the span
- 9) Thermal effect on hysteresis – effect the temperature has on the hysteresis

Total error = (non-linearity + hysteresis + non-repeatability) + long term stability + zero offset + span offset + thermal effect on span + thermal effect on span + thermal effect on hysteresis  
 Below are two typical pressure transducers and what their true accuracy is at actual reading:

	Pressure Transducer A ± 0.05 in. H <sub>2</sub> O Range ±0.5% Accuracy	Pressure Transducer B ± 0.1 in. H <sub>2</sub> O Range ±0.8% Accuracy
Non-linearity	± 0.49% FS	± 0.8% FS  (They publish the ±0.8% covers: Non-linearity, Hysteresis, and Non-repeatability. Also includes zero setting tolerance and span setting tolerance)
Hysteresis	± 0.05% FS	
Non-repeatability	± 0.05% FS	
Zero Setting Tolerance	± 0.5% FS	
Span Setting Tolerance	± 0.5% FS	
Stability per year	± 1.0% FS / YR	± 0.25% / YR
Thermal effect on offset	± 0.15% FS (0.03%FS/°F × 5F for a 5 degree delta T)	± 0.15% FS (0.03%FS/°F × 5F for a 5 degree delta T)
Thermal effect on span	± 0.15% FS (0.03%FS/°F × 5F for a 5 degree delta T)	± 0.15% FS (0.03%FS/°F × 5F for a 5 degree delta T)
Thermal effect on hysteresis	NOT PUBLISHED	NOT PUBLISHED
<b>Total Error from published data*</b>	<b>± 1.89% of FS at calibration*</b>	<b>± 1.10% of FS at calibration*</b>
Full scale value of Transducer	0.1 in. H <sub>2</sub> O (-0.05 to +0.05 in. H <sub>2</sub> O)	0.2 in. H <sub>2</sub> O (-0.1 to +0.1 in. H <sub>2</sub> O)
<b>True Accuracy at 0.012 in. H<sub>2</sub>O Differential</b>		
True Accuracy of the reading (Total Error X Full Scale) at Day 1	<b>± 0.0019 in. H<sub>2</sub>O*</b>	<b>± 0.0022 in. H<sub>2</sub>O*</b>

\*Does **not** include the error for stability or thermal effect on hysteresis since it is not published.

Comparatively, the through the wall sensor is  $\pm 10\%$  of actual reading. Side by side comparison shows the true differentiation:

Through The Wall Sensor	Pressure Transducer A	Pressure Transducer B
$\pm 10\%$ of Actual Reading	$\pm 0.05$ in. H <sub>2</sub> O Range $\pm 0.5\%$ Accuracy	$\pm 0.1$ in. H <sub>2</sub> O Range $\pm 0.8\%$ Accuracy

$\pm 0.0012$ in. H <sub>2</sub> O	$\pm 0.0019$ in. H <sub>2</sub> O	$\pm 0.0022$ in. H <sub>2</sub> O
( $\pm 10\%$ of Actual Reading)	( $\pm 15.8\%$ of Actual Reading)	( $\pm 18.3\%$ of Actual Reading)

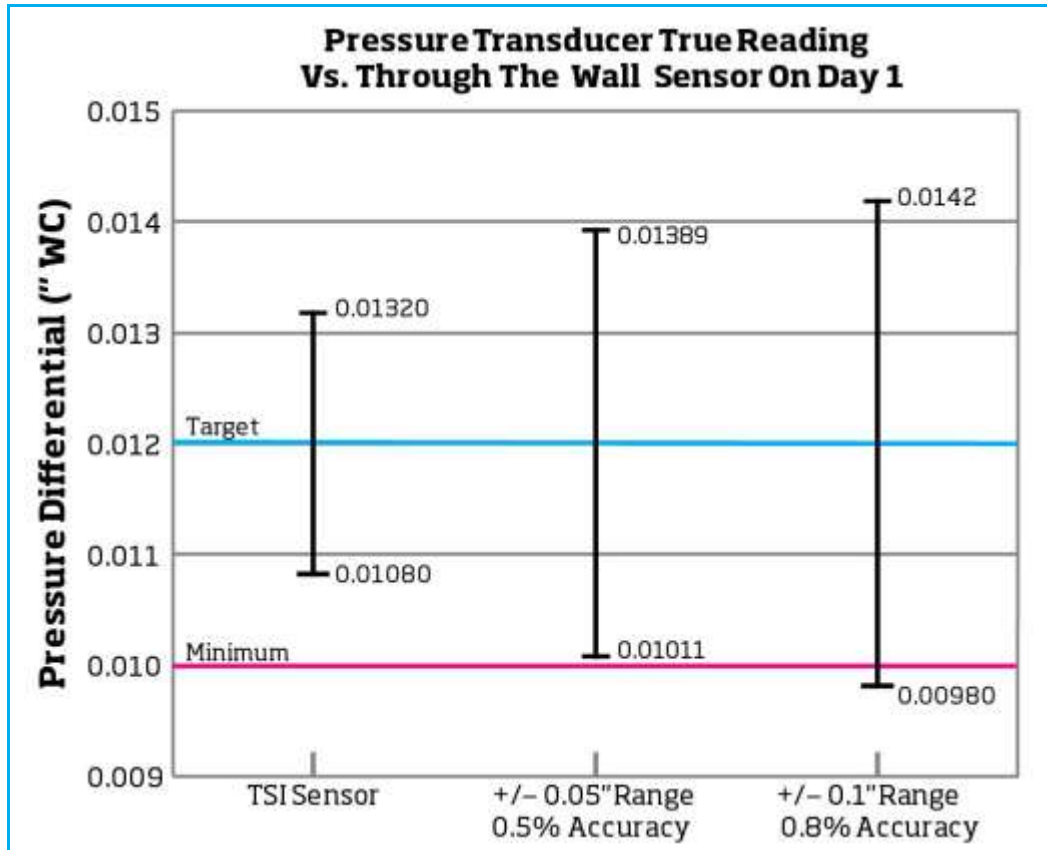

*Chart 1. Pressure Sensor True Accuracy on Day 1*

## Drift (Stability)

Sensor drift plays an important role in accurately monitoring the pressure differential in a critical space. As a sensor starts to drift from its calibrated zero set point, the sensor will no longer produce valid results, and can allow cross contamination of critical and clean spaces.

A TTW sensor using thermal anemometry uses solid state sensors for an extremely stable and consistent reading. It contains no moving parts, or bending diaphragms that can degrade with use over time. TSI manufactures similar sensors on Air Velocity meters; factory calibrations of these meters show minimal drift even after years of use. It is easy to see why the TTW sensor has been the stability benchmark for over 20 years.

Over time, all pressure transducers, no matter of the media or style, will drift. Regular calibration is a maintenance necessity for all pressure transducers in order to maintain a properly functioning sensor, and to protect the critical space. If calibration and resetting of the zero set point is not done on a regular basis, false positives or negatives may result and critical environment integrity can be compromised as shown in Chart 2. The speed at which the transducer drift becomes an issue

depends on the application, and the properties of the device. The good news is sensor drift can be kept under control with diligent and regular calibration. The bad news is that calibrating a pressure transducer can be costly and time consuming.

To show how much of an effect drift has on the same pressure transducers in the accuracy calculation, let's take into account the stability error into our calculations after just the first two years of use:

	Pressure Transducer A ± 0.05 in. H <sub>2</sub> O Range ±0.5% Accuracy	Pressure Transducer B ± 0.1 in. H <sub>2</sub> O Range ± 0.8% Accuracy
Total Error from published data*	± 1.89% of FS on Day 1*	± 1.10% of FS on Day 1*
Stability per year	± 1.0% FS / YR	±0.25% / YR
Total Error After Time	± <b>2.89% of FS at the end of year 1*</b>	± <b>1.35% of FS at the end of year 1*</b>
	± <b>3.89% of FS at the end of year 2*</b>	± <b>1.60% of FS at the end of year 2*</b>
Full scale value of Transducer	0.1 in. H <sub>2</sub> O (-0.05 to +0.05 in. H <sub>2</sub> O)	0.2 in. H <sub>2</sub> O (-0.1 to +0.1 in. H <sub>2</sub> O)
<b>True Accuracy</b>		
True Accuracy of the reading (Total Error X Full Scale) at calibration	± 0.0019 in. H <sub>2</sub> O*	± 0.0022 in. H <sub>2</sub> O*
<b>True Accuracy of the reading at the end of year 1</b>	± 0.0029 in. H <sub>2</sub> O* (±23.3% of Actual Reading)*	± 0.0027 in. H <sub>2</sub> O* (±22.5% of Actual Reading)*
<b>True Accuracy of the reading at the end of year 2</b>	± 0.0039 in. H <sub>2</sub> O* (±31.7% of Actual Reading)*	± 0.0032 in. H <sub>2</sub> O* (±26.7% of Actual Reading)*

\*Does **not** include the error for thermal effect on hysteresis since it is not published.

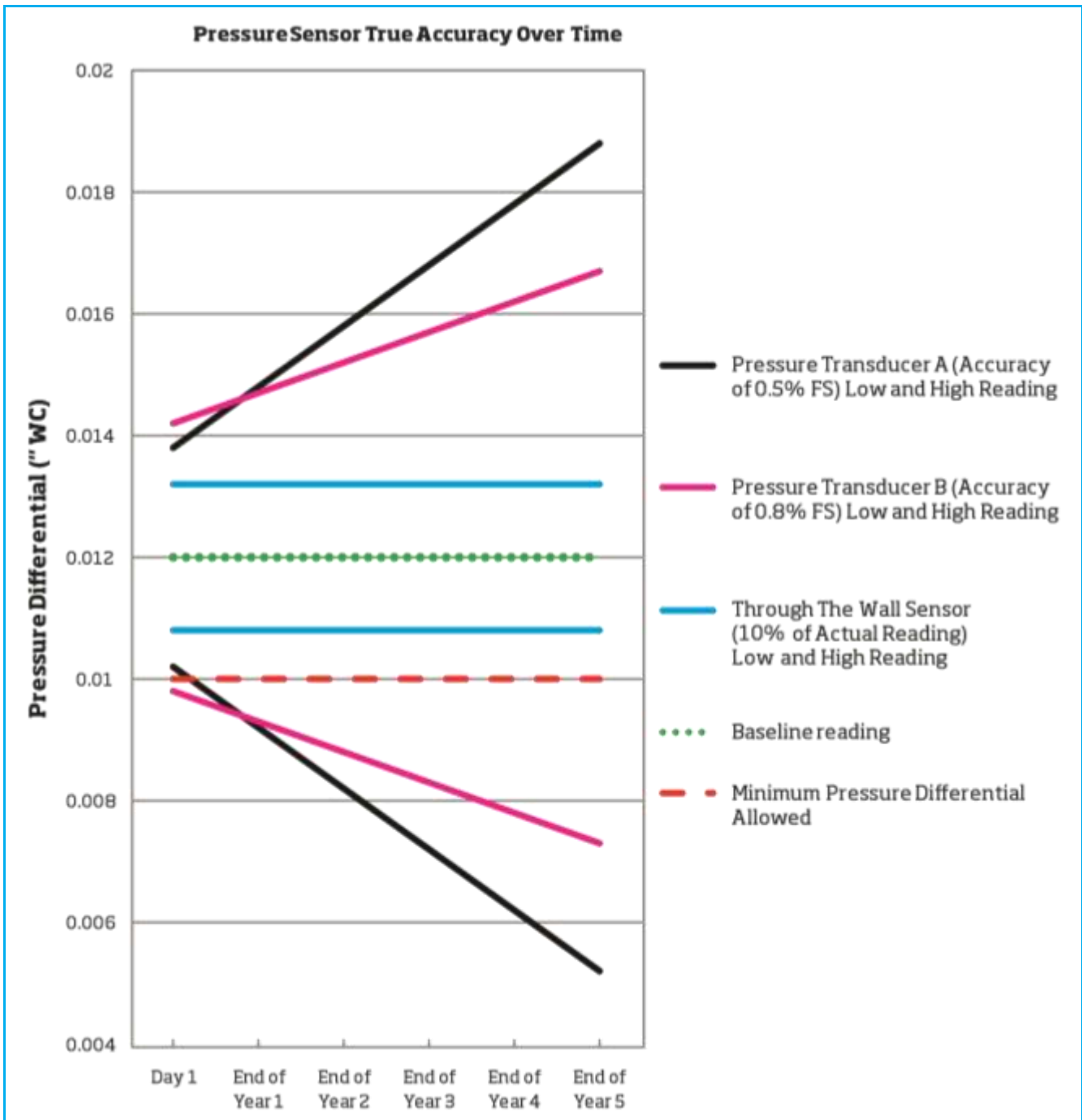

**Chart 2.** Pressure Sensor Accuracy Over Time with Lack of Calibration

If these pressure transducers are not frequently recalibrated, they can indicate a sufficient pressure differential when it doesn't exist, risking loss of containment and the spread of infection through a health-care facility.

## Calibration Issues

Most mechanical equipment needs maintenance or calibration. Hospital room pressure measurements are no different. TSI's TTW sensor is easy to calibrate whereas pressure transducers can present some concerns.

With a TTW sensor, the calibration is done on site with a hot wire anemometer and a smoke generator. This requires about \$1,000 worth of standard tools that facility engineers and TAB contractors readily possess. Smoke is used to verify the direction of airflow while the anemometer calibrates the sensor. Calibration includes a quick zero adjustment and a digital span adjustment, both of which can be directly entered into the interface module – no additional equipment is needed. The TTW sensor is mounted in the hallway or the room for easy accessibility. There is no need to go above ceiling tiles or take products off the wall to perform calibration. The whole process takes only 5-10 minutes.

As Chart 2 shows, pressure transducers will need regular calibration due to drift. Calibration of some pressure transducers can be time consuming and requires expensive equipment. Some manufacturers claim a zero offset adjustment is sufficient to recalibrate their sensors. While this might be a quick fix for the zero offset, it provides no verification that the sensor is working properly and giving accurate readings. Physically accessing the actual pressure transducer can be a challenge. If the pressure transducer is mounted in a plenum space above the ceiling, access can be difficult as duct work, piping and wiring could be in the way. If the pressure transducer is mounted within the pressure monitor in the wall, the monitor must be removed from the wall to access the transducer for calibration.

In addition, calibrating a pressure transducer requires a very costly pressure generating calibration kit which can cost as much as \$10,000-\$15,000. In the calibration process, the sensor is connected to the pressure generator. A known pressure is then sent to the sensor, and the process of calibration begins. This is an iterative process of adjusting the span and zero potentiometers, and repeating both adjustments multiple times until the sensor finally reads the correct pressure. A professional can usually recalibrate a pressure transducer correctly in about an hour.

---

## Conclusion:

When designing a critical space, safety is the primary concern for everyone. The space must maintain the minimum pressure differential of 0.01 in. H<sub>2</sub>O. The sensing device must have sufficient accuracy and reliability to make this measurement. The sensor must also require minimal maintenance and with minimal drift to keep the costs down for the owners. Based on these criteria, TSI's through the wall sensor provides superior benefits for an owner and has been the gold standard for room pressure sensors for many years. A summary comparison of the technologies is shown below.

	Thermal Based Pressure Sensor	Pressure Transducer
Initial Accuracy At Calibration	●	●
Stability	●	●
Calibration Costs	●	●



TSI Incorporated – Visit our website [www.tsi.com](http://www.tsi.com) for more information.

USA Tel: +1 800 874 2811  
 UK Tel: +44 149 4 459200  
 France Tel: +33 4 91 11 87 64  
 Germany Tel: +49 241 523030

India Tel: +91 80 67877200  
 China Tel: +86 10 8251 6588  
 Singapore Tel: +65 6595 6388



Distributed by:  
 Kenelec Scientific Pty Ltd  
 1300 73 22 33  
 sales@kenelec.com.au  
 www.kenelec.com.au